

ENS26 Automatic Isolation Unit Product Description

Issue 09/2005

UfE Umweltfreundliche Energieanlagen GmbH
Joachim-Jungius-Straße 9
D-18059 Rostock

Tel.: +49 3 81 / 405 97 05

Fax: +49 3 81 / 405 97 03

E-mail: post@ufegmbh.de

web: www.ufegmbh.de



Note

If you have any queries and need to contact UfE GmbH, always have the serial number close to hand in order to make reference to it. We do not claim the documentation is free of errors and mistakes. Please inform UfE GmbH of any errors found in the documentation.

© Copyright

This Product Description is the copyright of UfE GmbH.

This manual is intended for the customers and project planner. It contains instructions and information which must not be copied, distributed or transferred by technical data methods nor used for the purpose of competition, either as an entirety or as extracts, without the necessary authorisation.

Contravention could lead to prosecution and obligation to pay damages.

All rights reserved, particularly in the case of patent application or other registrations.

We reserve the right to make technical modifications without notice.



Note

The ENS26 isolation unit and the measuring method are protected by patent.

1	Purpose of the Product	4
2	System Description	5
2.1	Principles of functioning.....	5
2.2	LCD display and LEDs	6
2.3	Connections	7
3	Behaviour of the Isolation Unit	8
3.1	General information	8
3.2	Fluctuations in the mains power supply.....	8
3.3	Deviation of the mains power frequency.....	9
3.4	Impedance jumps	9
3.5	Influence of isolation units on each other	10
3.6	Optimised impedance measurement process	10
3.7	Automatic calibration of the impedance measurement ..	11
3.8	Automatic adaptation of switching thresholds to the mains power conditions	12
3.9	Automatic synchronisation / limitation of signal strength in the case of frequent use of the ENS	13
4	Installation	14
4.1	Mechanical installation	14
4.1.1	Transport and unpacking	14
4.1.2	Conditions for installation	14
4.1.3	Preparing the electrical/meter cabinet	15
4.1.4	Mounting on the top hat rail	15
4.2	Electrical connection.....	16
4.2.1	Basic configuration	16
4.2.2	Circuitry	16
5	Advantages for the Customer	18
6	Technical Data	19



1 Purpose of the Product

The automatic, one-phase isolation unit is an automatic switching unit used to connect decentralised power generators safely to the public electricity supply.

The ENS26 isolation unit has been conceived as an independent unit for monitoring one-phase power feeding systems. It prevents uncontrolled island effects following failure or shutdown of the public electricity supply.

The ENS26 complies with DIN VDE 0126-1-1 and is approved as a substitute for manual isolation devices up to a 5.75 kW feeding power.

By implementing this automatic isolation unit, it is possible to dispense with a manual isolation unit which must be accessible to the public electricity supply authorities at all times.

The feeding systems (one-phase systems) can be:

- photovoltaic systems,
- small hydroelectric power stations,
- block-type thermal power stations,
- fuel cells,
- small wind energy plants.

2 System Description

2.1 Principles of functioning

The ENS26 automatic isolation unit continually monitors

- overvoltage and undervoltage
- frequency deviation
- impedance jumps

in the public electricity supply.

In the event of faults in the mains supply, the ENS26 interrupts the feeding of electricity in the mains to prevent island effects.

The disconnection of L and N is accomplished by two relays. Each relay is specified for a switching current of 25 A.

The contact distance within the relay is in accordance to the overvoltage category 2 at 250 V AC.

The safety functions are executed in a dual channel system, whereby each channel monitors the proper function of the other channel. In case of a failure the channels disconnect independently from each other.

The channels monitor each other mutually (refer to the error protection in accordance with DIN VDE 0126) to increase error protection. Therefore, recurrent tests can be dispensed with.



Note

Further information on the principles of functioning is available on our Internet site at www.ufegmbh.de.

2.2 LCD display and LEDs

The following indicators are provided on the front side of the ENS26:

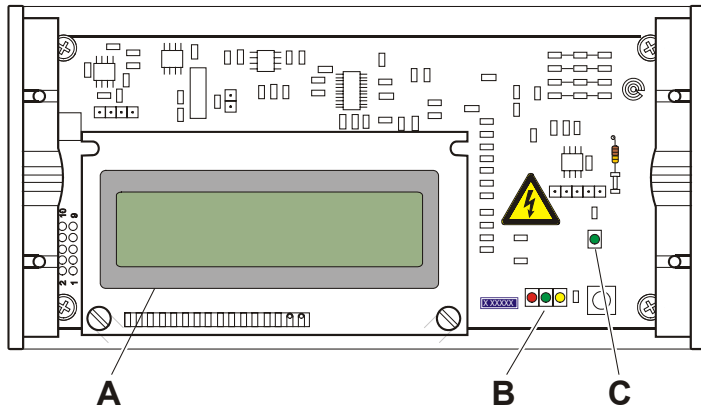

A) LCD display (optional)

The equipment status as well as the status of the monitored phase are provided in a 2-line LC display. Each line can contain 16 characters.

B) LEDs of the phase monitoring

In addition to the optional LCD display, the unit status and status of the monitored phase are also indicated by the three LEDs (red, green, yellow):

C) LED of the self-monitoring (green)

This LED flashes during normal operation and indicates that the self-monitoring feature is active.



Note

The meaning of the LCD display and LED indicators is described in the Operating Manual.

2.3 Connections

The following connections are provided at the top edge of the ENS26:

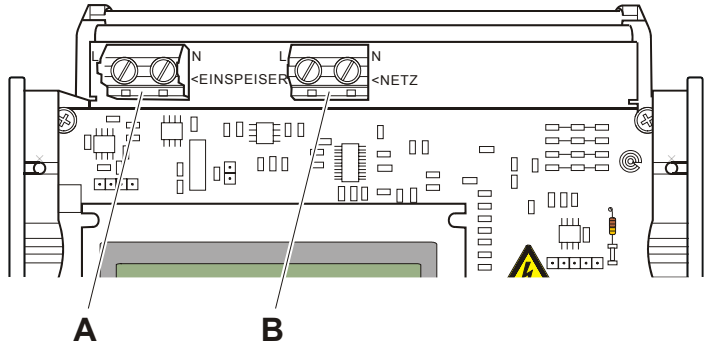

- A** 2 connection terminals to connect one phase and the neutral conductor (feeding unit)
- B** 2 connection terminals to connect one phase and the neutral conductor (mains)



Note

The connection of the unit is described in the Installation Manual.

3 Behaviour of the Isolation Unit

3.1 General information

The ENS26 monitors the mains power supply and prevents uncontrolled island effects developing in the event of a power failure or the mains being switched off.

It reacts to fluctuations in:

- voltage,
- frequency,
- impedance.



Note

The default settings can be changed, if necessary. The ENS manufacturer must be informed of these requirements, however, prior to configuration.

3.2 Fluctuations in the mains power supply

The threshold values for the mains power supply are set as follows:

Fluctuation	Threshold value	Test interval
Overtoltage	300 V	Every 20 ms (fast shutdown)
Overtoltage	264 V	Every 200 ms
Undervoltage	130 V	Every 20 ms (fast shutdown)
Undervoltage	184 V	Every 200 ms
Average of the mains voltage above set value	253 V	10-minute average

3.3 Deviation of the mains power frequency

The testing of the frequency is performed directly at the mains voltage.

The threshold values for the mains frequency are set as follows:

Fluctuation	Threshold value	Test interval
Overfrequency	50.2 Hz	Every 200 ms
Underfrequency	47.5 Hz	Every 200 ms

Channel 1 also measures the phase position between the outer conductors. In the event of a **phase difference in excess of 30 degrees**, the feeding point is disconnected from the power supply.

If the rate of change of the frequency (RoCoF) exceeds **1 Hz/s**, disconnection from the supply is also triggered.

3.4 Impedance jumps

The mains impedance is monitored. The time-dependent change of voltage near the crossover (phase shift), caused by test signals, with various voltage values forms the basis for calculating the mains impedance.

All the impedances measured in one second are used to establish an average value. The number of measuring pulses is dependent on the number of ENS connected in the network.

Depending on the power characteristics, the triggering threshold for an impedance jump is adapted between 1 ohm and 0.2 ohm.



Note

A threshold of 0.5 ohm is set ex works.

The automatic adaptation of the switching threshold is described in Section 3.8.

3.5 Influence of isolation units on each other

When isolation units of the type ENS26 are used, they can be implemented in dense proximity in the public electricity supply without it leading to operational problems. Even in the case of long network spurs and a mains supply subject to frequent faults, unproblematic operation can be guaranteed.

The ENS26 automatically adapts to these difficult power supply conditions. To achieve this, the following processes are integrated in the ENS26:

- optimised impedance measurement process,
- automatic calibration of the measured impedance change,
- automatic adaptation of switching thresholds to frequent fluctuations and interference levels
- automatic synchronisation and limitation of signal strength in the case of frequent use of the ENS

3.6 Optimised impedance measurement process

The optimised impedance measurement process improves the resolution and interference resistance of the impedance measurement on a large scale. Centralised ripple control signals and frequency converters hardly influence measurements.

An island effect is recognised by a sudden increase in the mains power impedance.

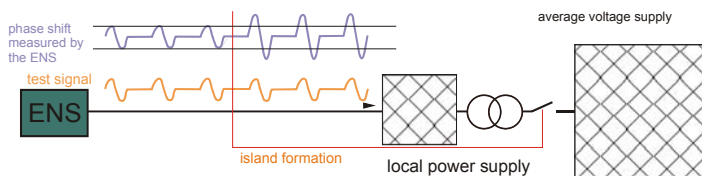

3.7 Automatic calibration of the impedance measurement

A precision resistor in the ENS performs an automatic, continuous calibration of the impedance measurements and, at the same time, a continuous, automatic self-test. Manual calibration is no longer necessary.

To complete the calibration, the precision resistor is electronically bridged several times per second and the resulting impedance changes used as a reference for the calibration.

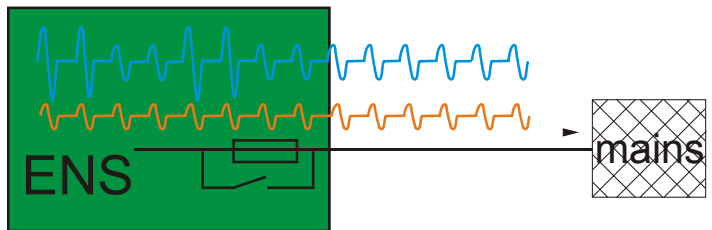

3.8 Automatic adaptation of switching thresholds to the mains power conditions

A distinction can be made between an overreaction of the ENS and an uncontrolled island effect. In the case of an overreaction by the ENS, the power supply remains available after disconnection of the feeding point from the mains.

If an overreaction is detected, the switching threshold for the next shutdown is adapted to a value which is a little above the current threshold value that has led to a shutdown.

Before the switching threshold is adapted to a less sensitive value, the ENS26 switches off briefly in order to check whether the power supply is still available. The threshold is only changed to a less sensitive value when it is recognised that the situation does not concern an uncontrolled island effect. In the case of stable, undisturbed mains supply feeding points, the switching threshold is slowly set to a value (i.e. over several days) which is about double that of the recurrent fluctuations which occurred (safety clearance). As a result of this automatic adaptation to the mains power conditions, safety is considerably increased without limiting the availability of the system.

If the interference level repeatedly exceeds the switching threshold, the switching threshold is incremented and the slow adaptation begins again from the start.

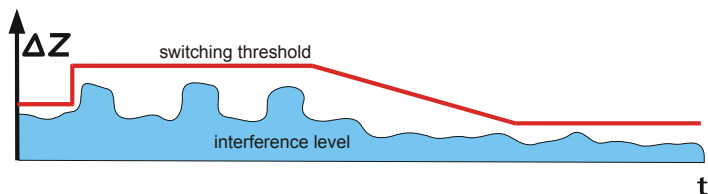

3.9 Automatic synchronisation / limitation of signal strength in the case of frequent use of the ENS

A “team” of parallel connected ENS units at the same feeding point generate a joint, stronger test signal through synchronisation. This enables even higher measuring accuracy. Faulty triggering is practically zero and operation is more stable.

The parallel connected ENS units generate a “decentral test tone”. As the number of ENS devices increases, more and more enter a passive operating state. They only generate a few signals themselves and use the jointly generated test signal as a pilot tone which can be measured at the mains power connection point.

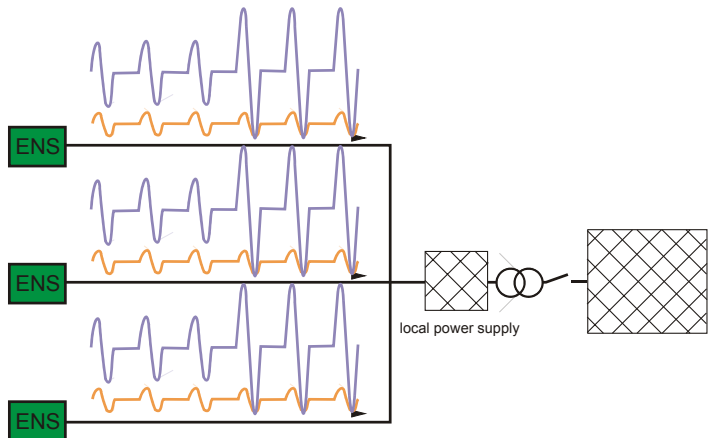

4 Installation



Danger

This chapter only serves for informative purposes. The actual installation must be performed according to the instructions in the Installation Manual enclosed.

4.1 Mechanical installation

4.1.1 Transport and unpacking

When transporting the ENS26 isolation unit, pay attention that it is always protected against contact with dirt and damage through impacts and setting down too hard.

Remove the ENS26 from the transport packaging and pull off the protective foil, if necessary.

After transport and before installation, check that the ENS26 isolation unit is in a perfect condition.

4.1.2 Conditions for installation

The ENS26 is intended for installation on a top hat rail in an electrical cabinet or in a meter cabinet. It cannot be installed anywhere.

The cabinet must be sufficiently large to house the ENS26 and protect the unit from moisture, dust, dirt and heat.

If there is not enough space in the cabinets available, a separate electrical cabinet must be mounted to accommodate the ENS26.



Attention

Never position the electrical cabinet containing the ENS26 above or in the vicinity of a heater. Ensure sufficient ventilation.

The ENS26 should be mounted as near as possible to the mains power outlet and as far as possible from the electricity feeding source.



Note

These measures reduce the effect of voltage increase by the current source.

4.1.3 Preparing the electrical/meter cabinet

Determine the installation position of the ENS26 on the top hat rail.

Saw a cut-out in the cabinet cover at the installation position of the ENS26 so that you can see the ENS26 and its indicators (LEDs and optional LCD) without opening the cabinet.

The cut-out must have the following dimensions:

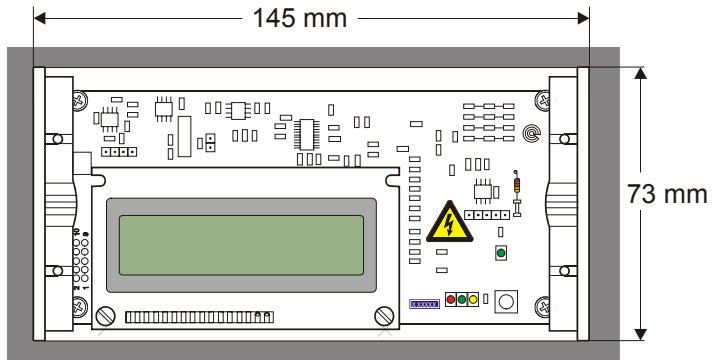

4.1.4 Mounting on the top hat rail

Set the isolation unit with its top housing holder (A) on the top hat rail and turn it downwards against the top hat rail (B). Use a little force to press on the bottom housing section until the housing holder engages in the top hat rail.

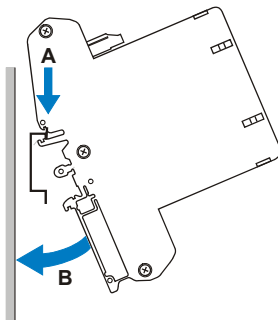

4.2 Electrical connection

4.2.1 Basic configuration

The ENS 26 is connected directly and without any switchin elements between the mains and the feeding point of a phase.



Danger

Connection to the public electricity supply may only be performed by a properly qualified and authorized electrician.

The ENS26 must be protected by a pre-fuse in the respective phase of the mains feed circuit (min. 6 A, max. 25 A). Observe the circuit diagram.

4.2.2 Circuitry

Check that the mains power lines and power feed line (phase) are not conducting electricity.

Switch the power generator (feeder) and the ENS26 as follows:

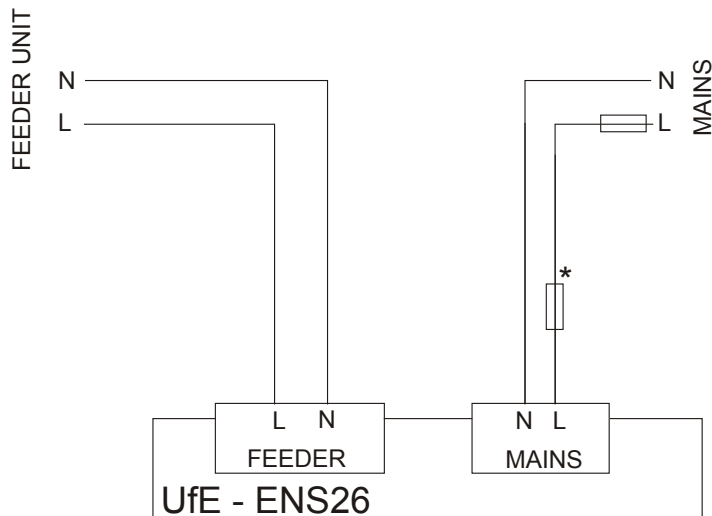

Note

The additional pre-fuse () is only necessary if the direct mains power fuse protection exceeds 25 A.*

The terminals on the ENS26 are arranged as follows:

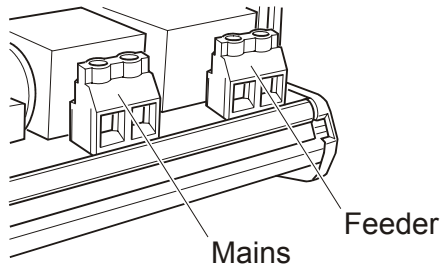

Attention

*The ground conductor should always bypass the unit. The neutral conductor **MUST** be connected to the ENS26 otherwise the unit may be damaged.*

If the ENS26 is switched on and off by means of a system control unit, the phase connection (L) of the ENS26 can be switched by means of a relay.



Note

When switching on via a relay, the delay until the contactors are activated can be up to 30 seconds because the ENS26 must test the power feed conditions again.

5 Advantages for the Customer

Customers have the following advantages:

- simple connection, easy installation,
- high degree of safety through monitoring voltage, frequency and impedance jumps,
- high degree of reliability through automatic, continuous calibration of the impedance measurement,
- continuous automatic self-test of the isolation unit,
- replaces the isolation unit provided by the public electricity supplier which must be permanently accessible,
- avoids inadvertent triggering through automatic adaptation of switching thresholds to the mains supply conditions,
- minimum energy consumption, minimum heating up,
- automatic, maintenance-free operation without recurrent tests,
- automatic synchronisation and limitation of signal strength following frequent use (several ENSs in local mains power supply).

6 Technical Data

Switched power	max. 5750 W
Own consumption	1.5 W
Housing	Plastic, suitable for assembly on the top hat rail
Overall dimensions (W x H x D)	146 mm x 111 mm x 80 mm
Cut-out dimensions (W x H)	146 mm x 73 mm
Ambient conditions	- 20 °C to + 40 °C, 10 to 90 % relative humidity, non-condensating
Nominal current of power feeder	max. 25 A
The unit disconnects the mains under the following defined conditions (complying with standard DIN VDE 0126):	
Overvoltage (fast shutdown)	> 300 V (response time 0.02 s)
Overvoltage	> 264 V (response time 0.2 s)
Overvoltage (average)	230 V + 10% over 10 minutes
Undervoltage (fast shutdown)	< 130 V (response time 0.02 s)
Undervoltage	< 185 V (response time 0.2 s)
Frequency deviation	+ 0.2 Hz / -2,5 Hz (response time 0.2 s)
RoCoF = Rate of Change of Frequency	> 1 Hz/s
Impedance jump detection	> 0.5 Ohm (response time 0.5 s)



For your notes